



Assembly Instructions & General Overview

For Technical Assistance Please Call Conklin Office Furniture
at 800.817.1187 or email support@conklinoffice.com



1. General Overview & Assembly Order.....Page 3
2. Assembling the Structural Components.....Page 4-11
3. Power, Data, Power Poles and Cable Floor Boxes.....Page 12-17
4. Worksurfaces and Screen Brackets.....Page 18-24
5. Final Check.....Page 25



General Overview

Stretch™ benching is a modular system designed to be easy to install and specify as well as being easily re-configured. At the core of the system are the legs and cable trays., which are able to extend or retract to accommodate multiple work surface lengths without specifying additional components. The whole system can be assembled with two allen wrenches and a drill with a phillips head driver.

NOTE: BECAUSE STRETCH IS AN ADJUSTABLE WIDTH SYSTEM IT IS IMPORTANT TO LEAVE ALL FASTENING SCREWS ON WORKSURFACES AND CABLE TRAYS LOOSE UNTIL ALL WORKSURFACES HAVE BEEN PLACED AND SCREEN BRACKETS HAVE BEEN INSTALLED . ONCE ALL COMPONENTS ARE ALIGNED, SECURELY TIGHTEN ALL SCREWS.

Assembly Order

1. Assemble legs and cable trays
2. Place and position floor supporting storage
3. Lay in any cabling and power components
4. Place work surfaces and screen brackets
5. Fasten work surfaces to legs while leaving screen brackets in place but loose
6. Install screens into brackets and tighten brackets to screen and work surface
7. Level legs and floor supporting storage
8. Hang screen accessories
9. Tighten all screws!!!

Structural Component Assembly (Cable Tray & Support Leg)

Remove the two screws and flat plate from the receiver on the leg.



Insert teeth on cable tray into receiving slots on leg.



After inserting the teeth, the cable tray must be pushed down to lock the teeth into the leg (a rubber hammer may be used to assist). Re-install the two hole plate and tighten the screws to fully secure the cable tray.



Structural Component Assembly (Cable Tray & Support Leg)

There are four types of main support legs (two types of **single legs** and two types of **double legs**).

Single end legs are used at the end of runs or on both sides of a single free standing desk.

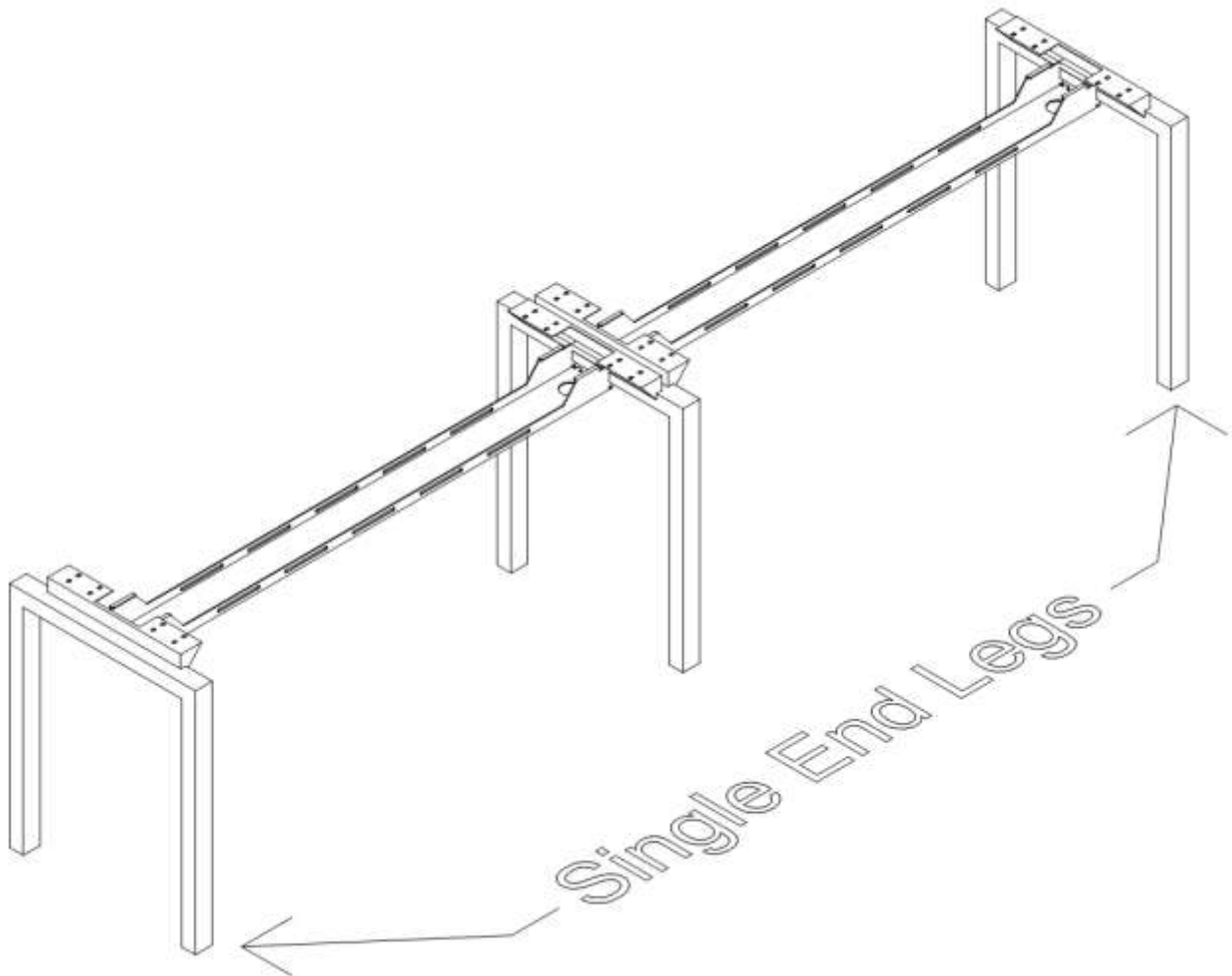

Structural Component Assembly (Cable Tray & Support Legs)

Single center legs are used in between desks in the middle of runs and have cable tray receivers on both sides.

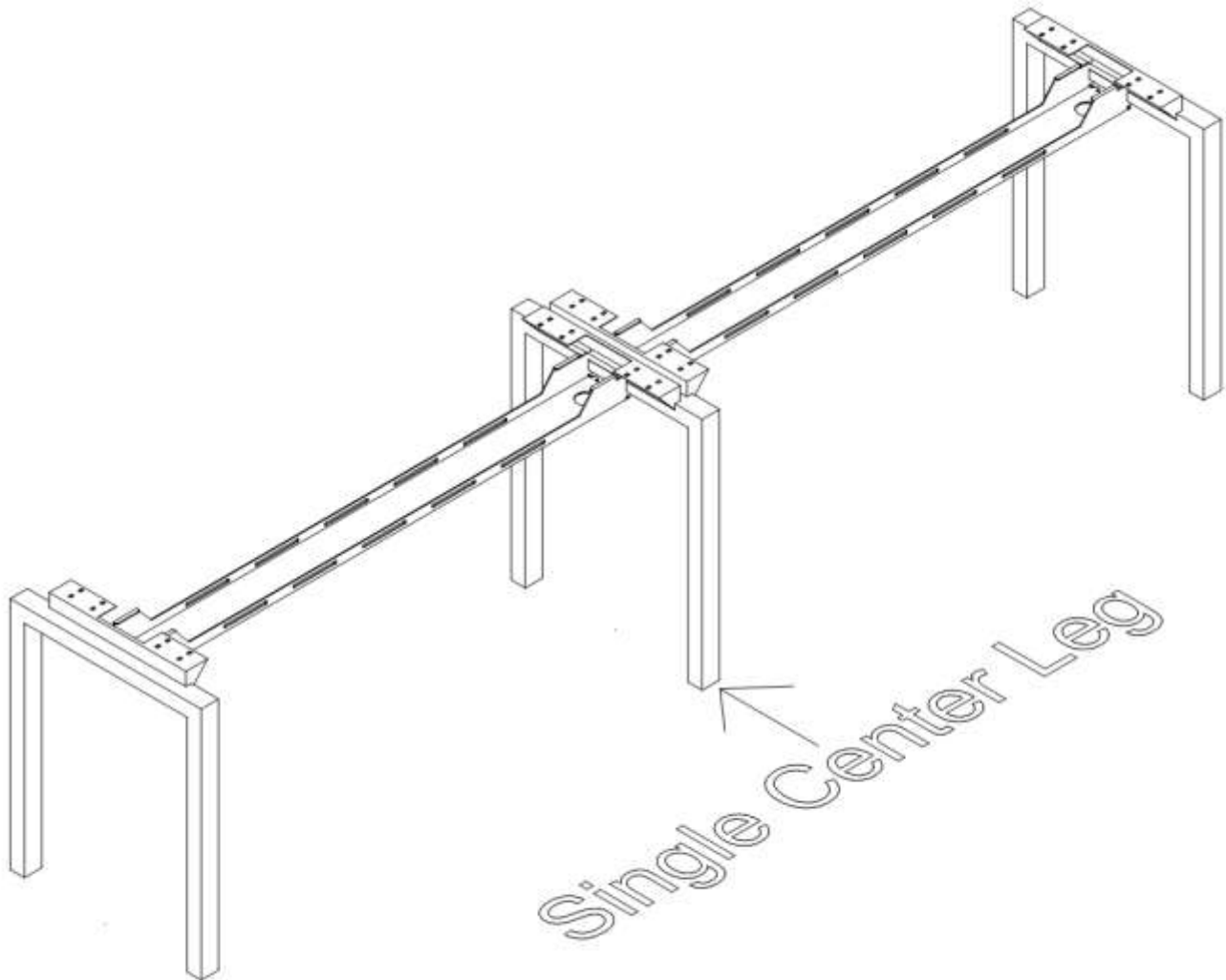

The double legs are used in the same manner as the single legs but are used for pods (back to back configuration)

Structural Component Assembly (Cable Tray & Support Legs)

The double legs are used in the same manner as the single legs but are used for pods (back to back configuration)

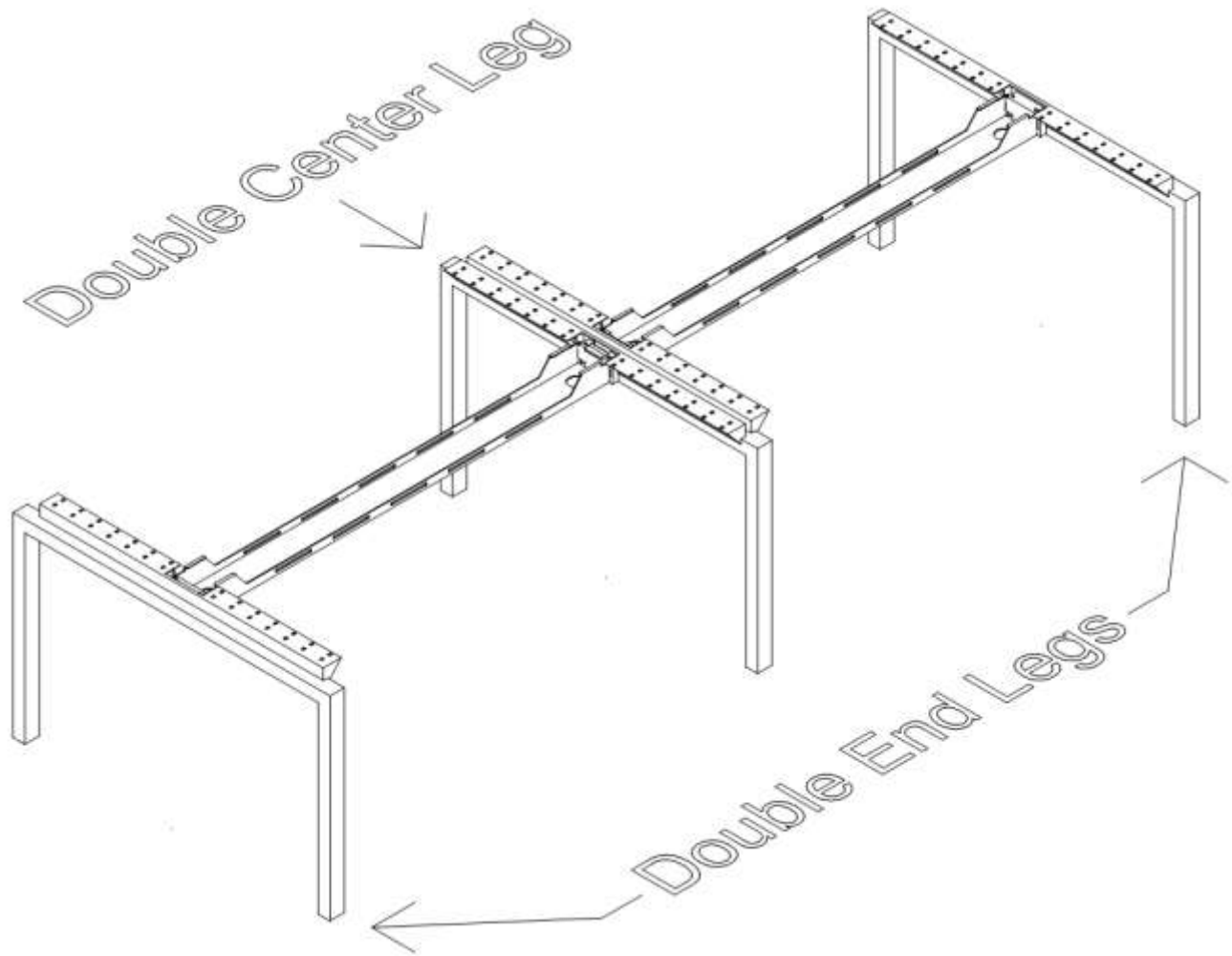

Structural Component Assembly (Cable Tray & Support Legs)

Under worksurface cable management can be added to return worksurfaces by using a 90 degree bracket.

90 Degree
Bracket

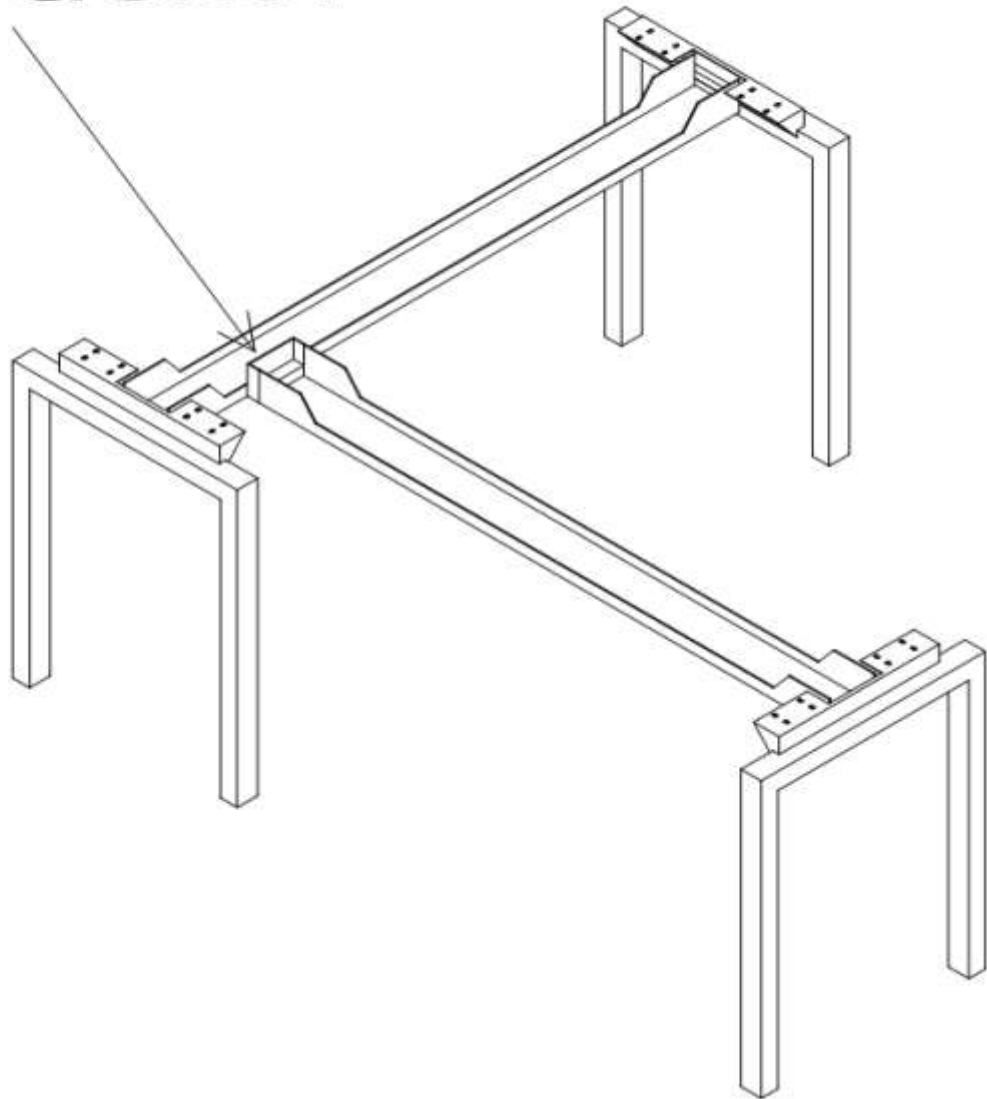

Structural Component Assembly (Brace Legs)

In addition to the main support legs there are four brace legs used for stabilizing when no return work surfaces are utilized. Brace legs are always installed perpendicular to End legs and Center legs. Two of the legs are used for single sided run configurations and two of the legs are used for pod configurations. Refer to pages 9 and 10 for typical placement.

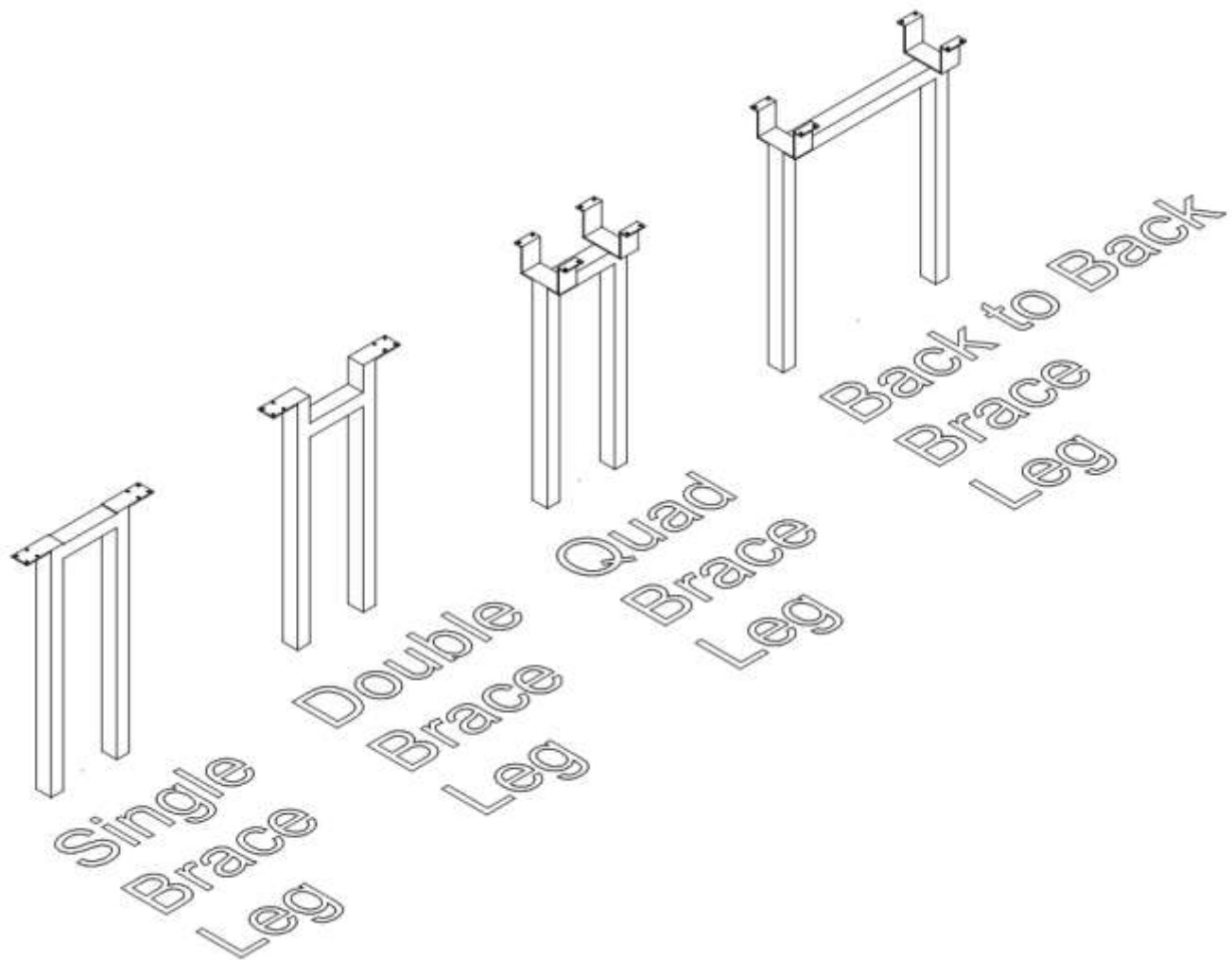

Structural Component Assembly (Brace Leg Single & Double)

The first two legs are used for single sided pods also know as runs (Single Brace Leg & Double Brace Leg). See below for typical installation locations.

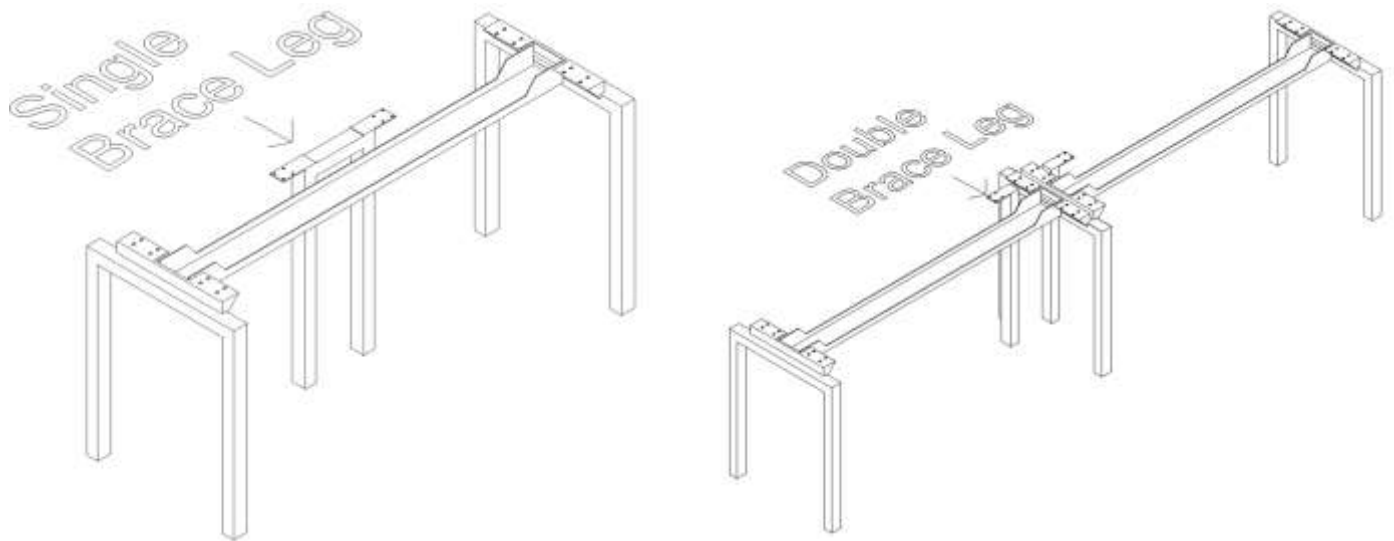

Note: When return work surfaces are utilized brace legs are not necessary.

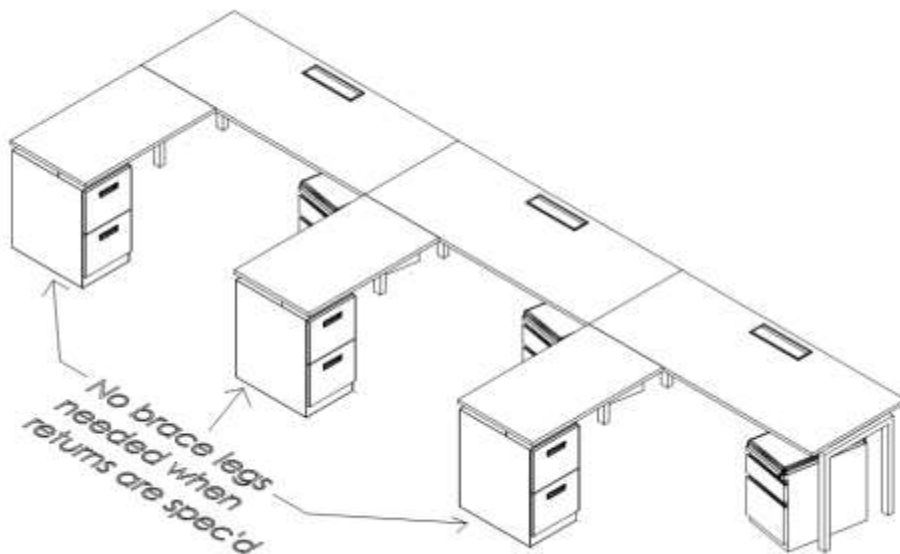

Structural Component Assembly (Brace Leg Quad & Back to Back)

The other two legs are used for double sided pods (quad brace leg & brace leg back to back). See below for typical installation locations.

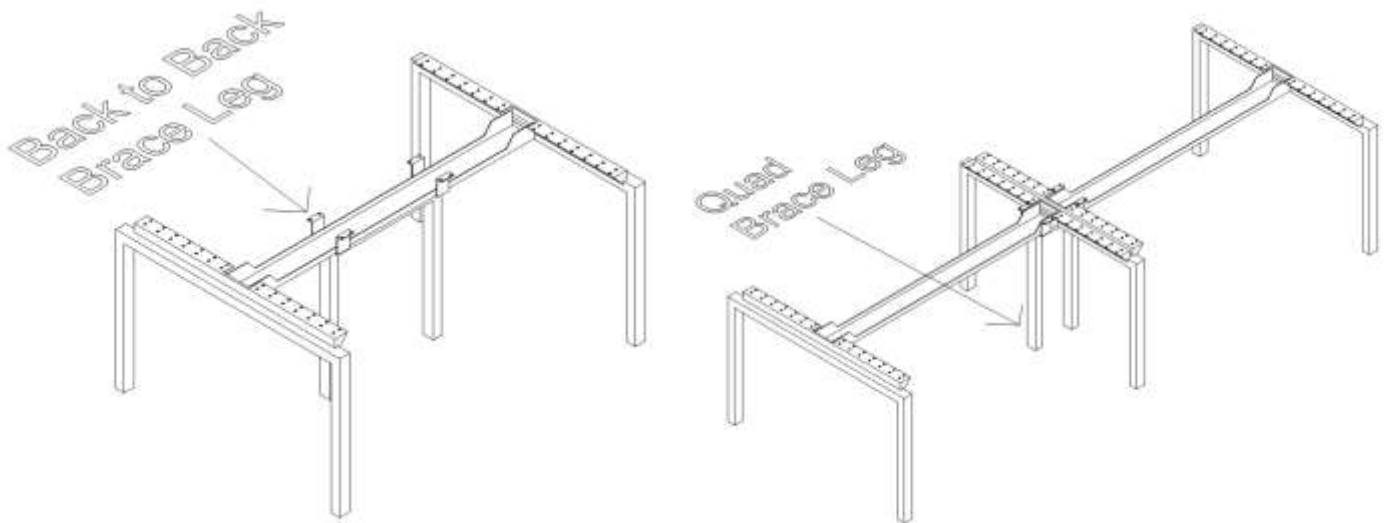

Note: When return work surfaces are utilized brace legs are not necessary.

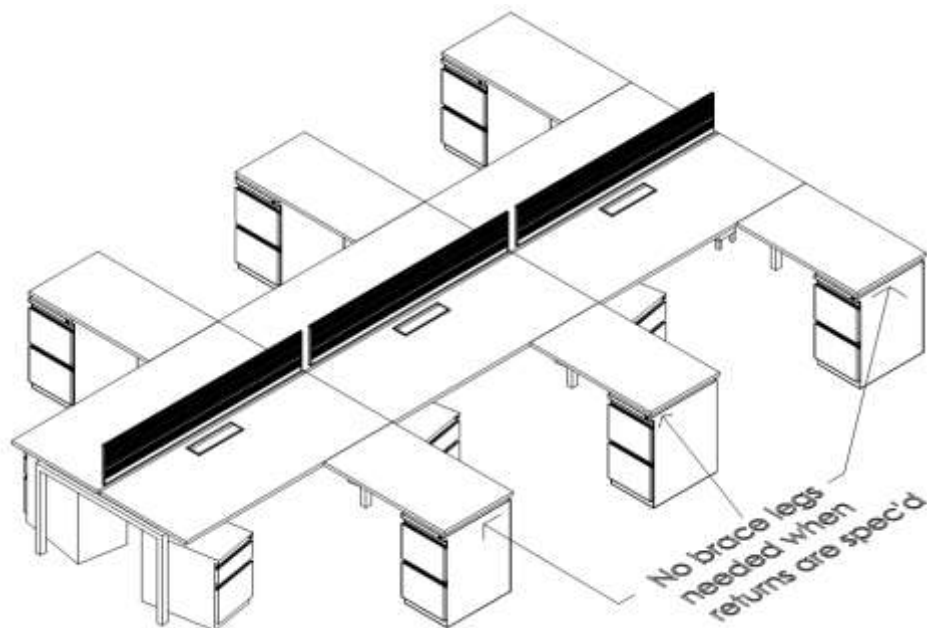

Power Components & Installation

Below are the components that make up the power system. Power Bar with duplexes, slide mount brackets and jumper or base infeed.



Power Components & Installation

Slide the brackets into the end of the cable tray as shown



Power Components & Installation

Slide the power bar on to the clips until secure.



Power Components & Installation

Connect base power infeed to power bar and connect jumpers between power bars.



When power bars are in the desired location install the 4 securing screws that came with the cable tray.



Cable Floor Box & Power Pole (Cable Routing)

The cable floor box is a hollow box elevated by four legs to allow cabling to pass underneath and then up to the cable tray.



The red line below shows the path of cable routing when coming from the wall or floor.

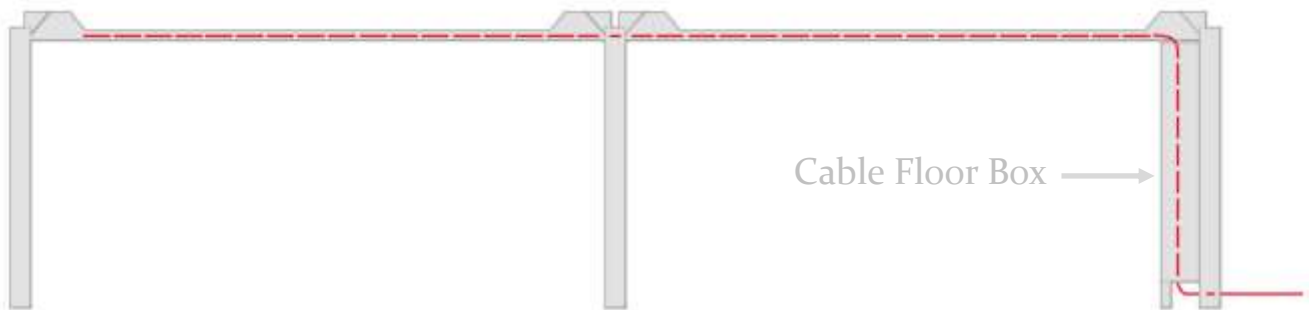

The red line below shows the path of cable routing when coming from ceiling through the power / data pole.

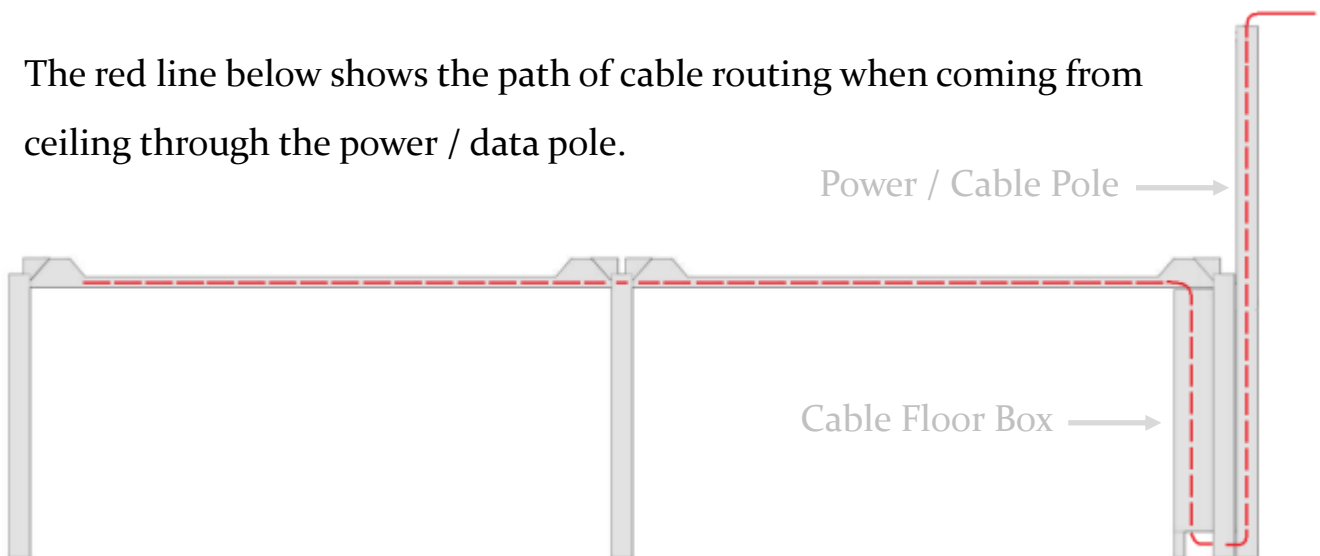

Network Cable Installation

Network cables shown installed in power way after power raceways and duplexes have been installed.



Center legs are cut out in the middle to allow cables to pass through to the next tray



Worksurface Installation

The main worksurfaces have threaded inserts pre-installed that match with the location of the holes on the primary Stretch legs. 6MM machine screws are used to attach the worksurface to the legs.

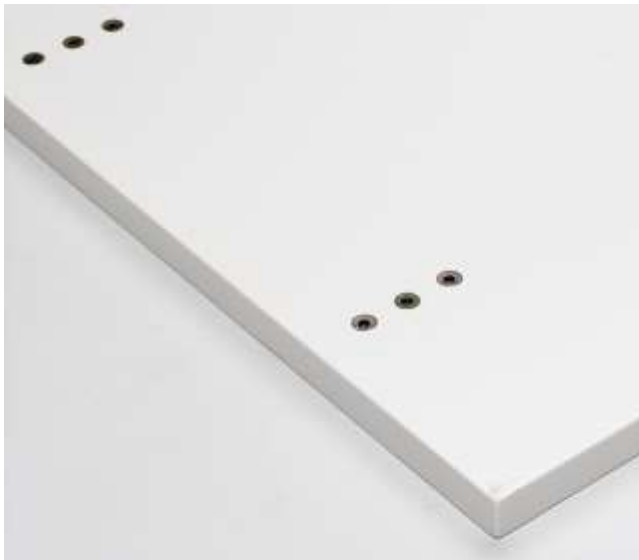

Worksurface Installation

On end of runs worksurface edge should be flush with the Stretch leg.

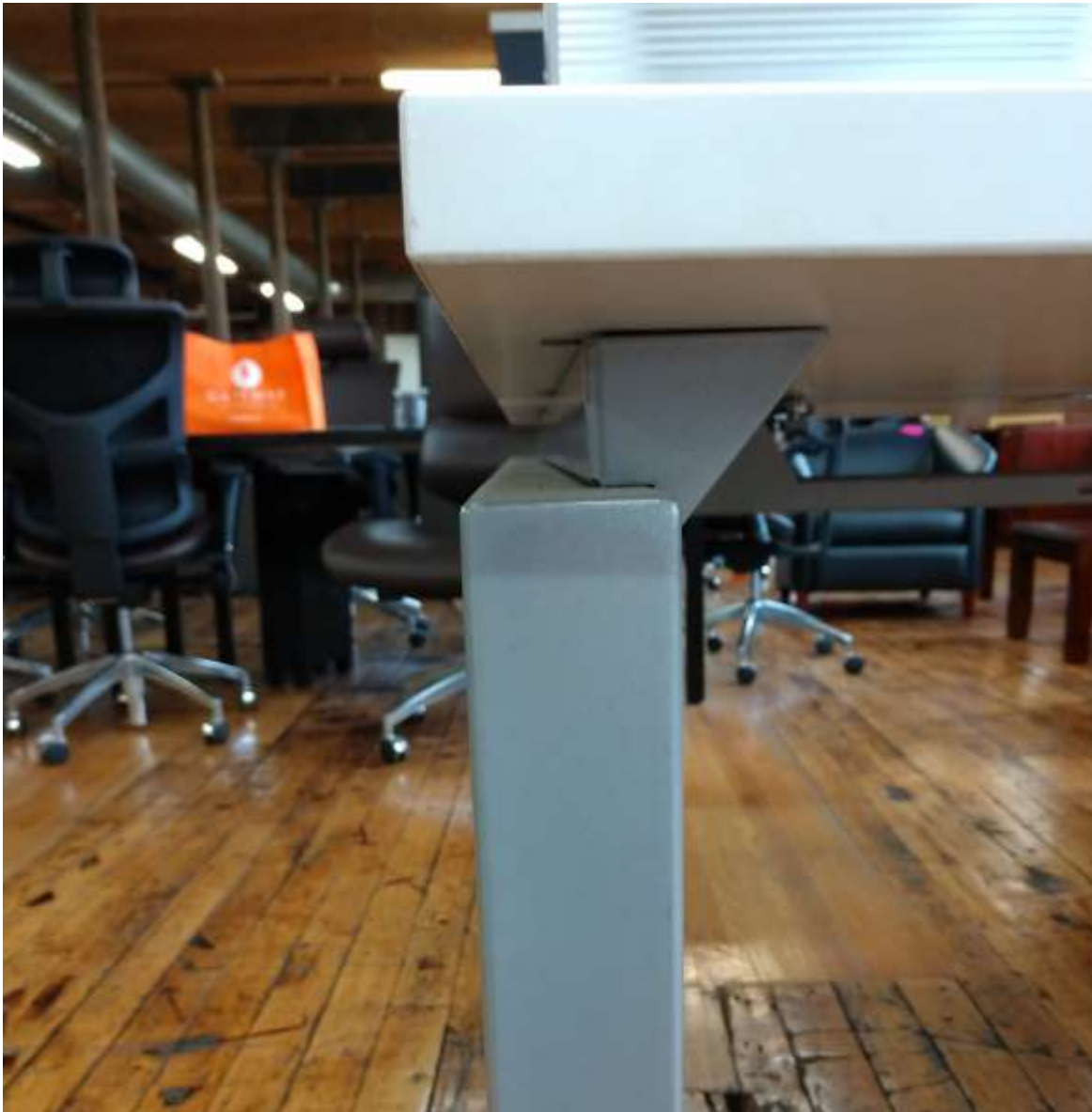

Worksurface Installation

Return worksurfaces are attached via wood screws and flat brackets to the main work surface.

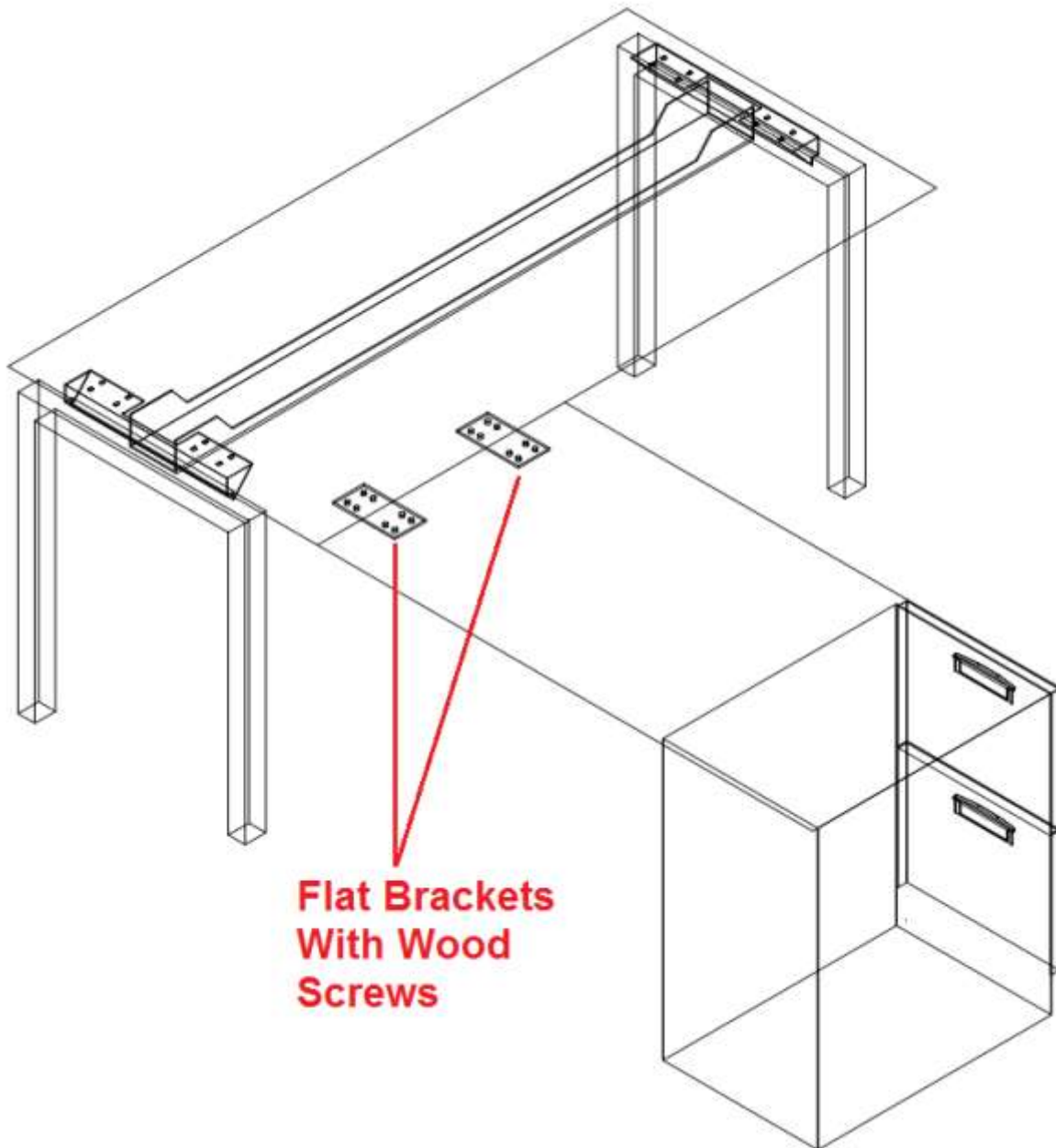

Worksurface Installation

Return worksurfaces are supported via a full height pedestal or with a single end leg.

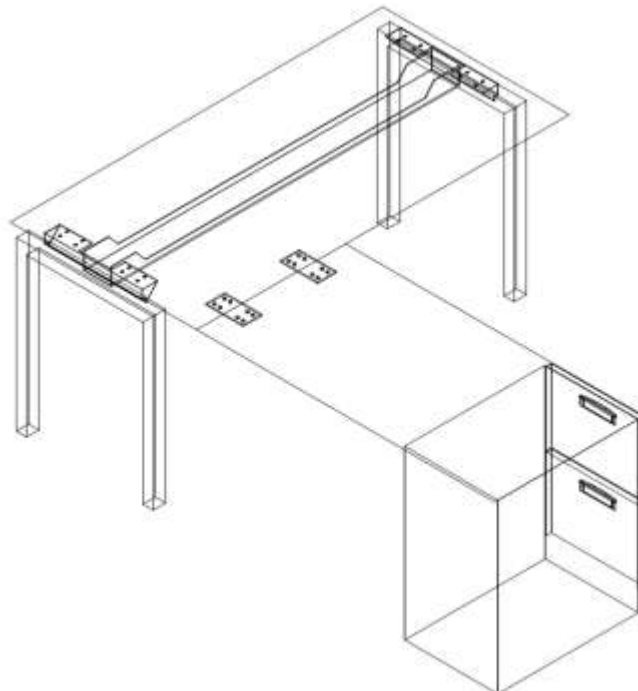
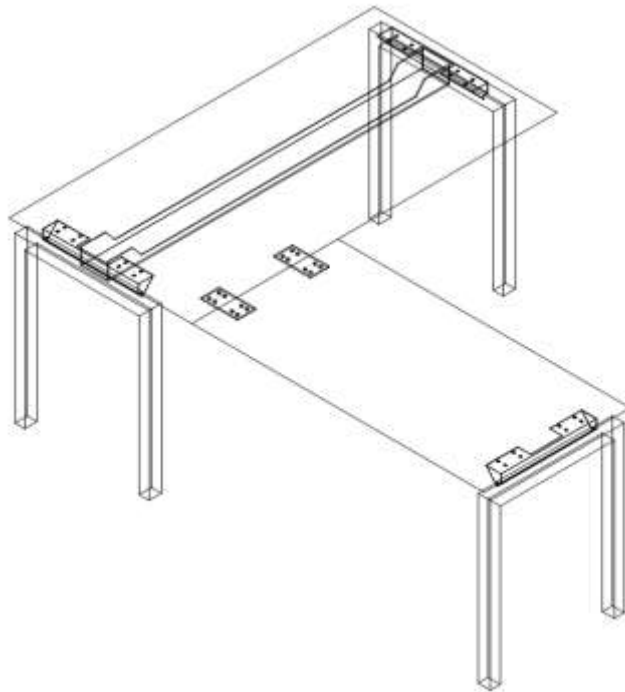

Screen Bracket Installation

Screen Brackets come with all parts necessary to install as a single sided application or double sided application. As well as tow sizes of rubber to accommodate either metal/fabric screens or glass screens.



Screen Bracket Installation (Single Sided Application)

Thread bracket down until it clamps the worksurface. Install two woodscrews through 5 hole bar into bottom side of worksurface.



Clip cosmetic bolt cover onto bolt as shown in the picture below

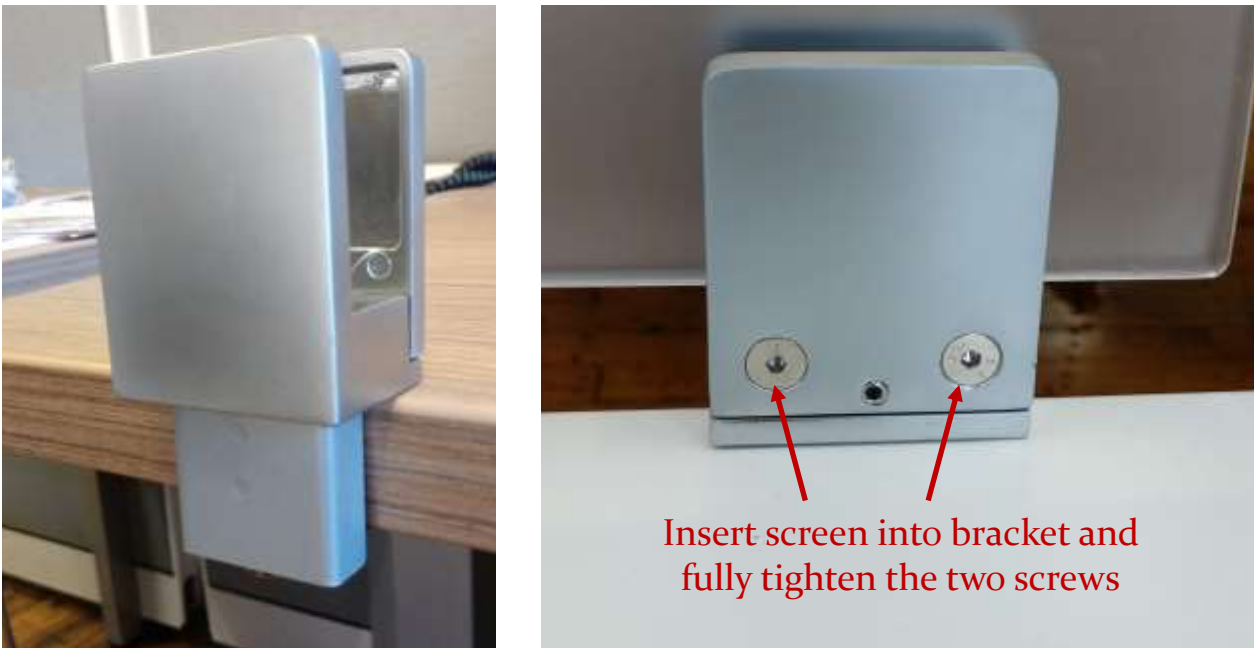

Screen Bracket Installation (Double Sided Application)

Single sided applications are installed as shown

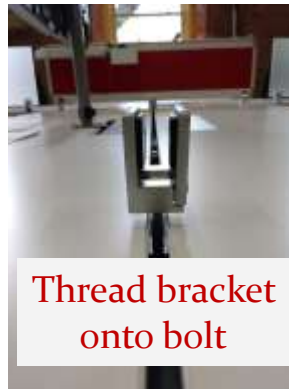

Install two wood screws on each end of 5 hole bar to bottom side of work surface



Final Check

1. Check tightness of leg to worksurface screws
2. Check that screen brackets are clamping screens with max clamping pressure
3. Check that screen brackets are fully tightened to the worksurface
4. Level all worksurfaces